



320Mpa

8~10%

--

 00220220

	mm	mm	mm	t/h	kw	t	mm
PF-1007	Ø1000×700	400×730	300	25-45	30-55	9.5	2400×1558×2660
PF-1010	Ø1000×1050	400×1080	350	50-80	55-75	12.2	2400×2250×2620
PF-1210	Ø1250×1050	400×1080	350	80-120	110-132	14.2	2690×2338×2890
PF-1214	Ø1250×1400	400×1430	350	100-160	132-160	18.5	2690×2688×2890
PF-1310	Ø1300×1050	490×1170	400	80-140	110-160	13.5	2780×2478×2855
PF-1315	Ø1320×1500	860×1520	500	150-220	220	20.9	3350×2718 55919 14

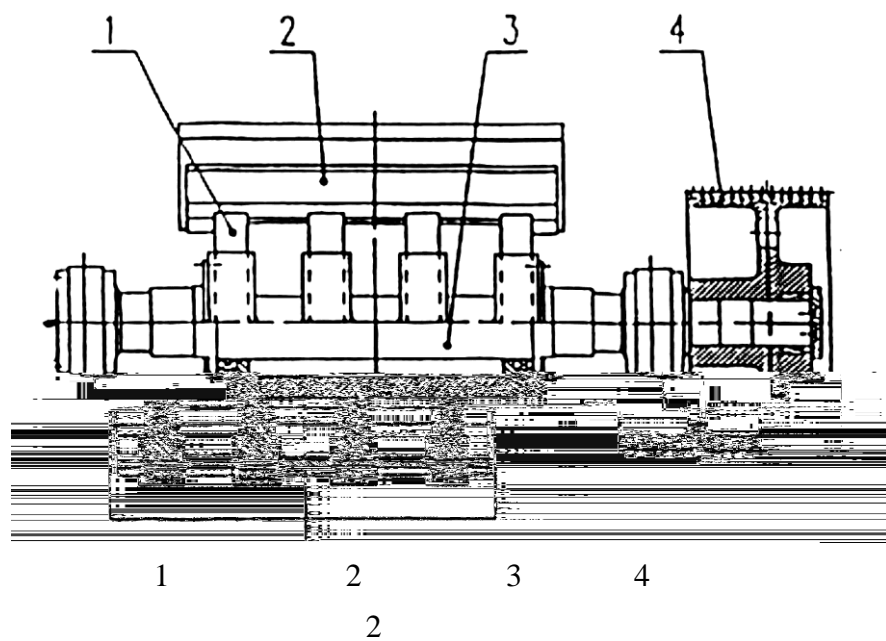

10mm

20mm

1

2

3

4

1

2

3

2

30

4



3

2

3

1

2

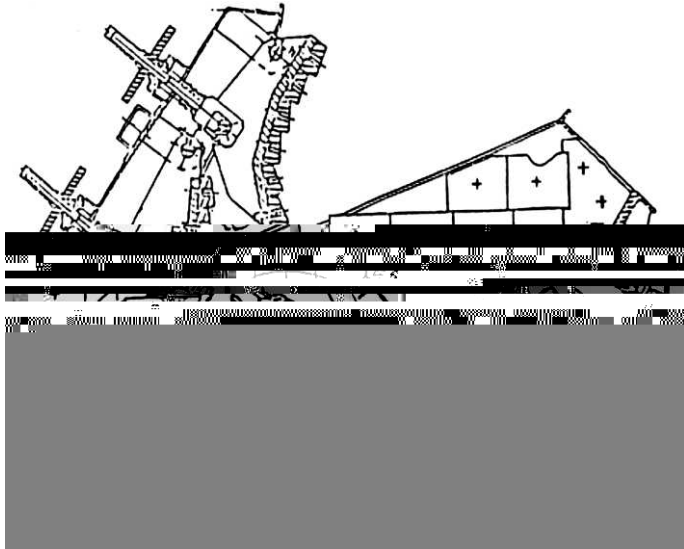

90 180

90

1/3MA 1/2MA

MA

MA=125N. m

3

6 /50

50-70%
